

Series 5

Touch Expert





MANUFACTURING TRADITION SINCE 1958.

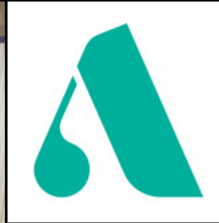

TECHNOLOGY, SERVICE AND ENGAGEMENT.

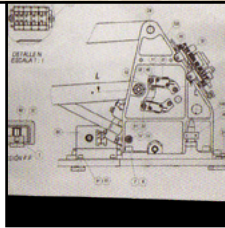



WELCOME TO ANCAR

■ In 1988, when we presented the Pyrinee model, our first dental unit and at the time the only model produced by Ancar, we could not have predicted, or even imagined, the impressive growth and recognition that the brand would have at the international level 30 years later.

In fact, it has not been easy to get here, but with a lot of determination, peace of mind and humility we have managed to forge a space and earn recognition in an extremely demanding and competitive market, while at the same time establishing the foundations of a consolidated and highly valued brand in 32 countries from Europe, the Middle East, Oceania and the Maghreb.

Since 1958, the passion for creation, innovation and design have been the basic elements of our activity, with the goal of offering professionals from the sector the highest quality, most durable and best performing treatment units.

Today more than 40 different models make up our range, all of them manufactured with aluminium. Ergonomic, technological and reliable solutions form the perfect base to develop a range of high performance dental units, with long-lasting quality and impeccable output.

Ancar's success over these nearly 60 years of history does not belong to one person or another: it belongs to everyone! Only true, honest and professional team work is capable of explaining our experience and ensuring our future.

“This is our history,
this is our philosophy,
this is our commitment”.

Antoni Carles Bosch
General Manager



Antoni Carles Pujol
President



Antoni Carles Bosch
General Manager

Series 5

Touch Expert



Welcome to the New Series:

treatment units with suspended chair and vertical elevation. Open space under the chair, without obstacles, allowing total freedom of leg movement for dentist and their assistants.

The ergonomic design means all components are integrated and coordinated together, so that any dental work can be done as well, comfortably and efficiently as possible.

The perception of looking at such a technologically advanced, customizable and different treatment unit that is almost unique, is transferred into the design and look of the consulting room. And, of course, made of aluminium.

New Series 5: undoubtedly the best choice!



Sd-550 *Touch Expert*

Electronic treatment unit
(Whip arm delivery system)



Sd-575 *Touch Expert*

Electronic treatment unit
(Hanging hose system)



Sd-580 *Touch Expert*

Electronic treatment unit
(Unit + cart Cd-80 *Touch Expert*)

GO UP IN THE
WORLD!
In innovation,
in design,
in expectations.

TECHNOLOGY

Touch Expert

THE TREATMENT UNITS OF THE NEW SERIES 5 FROM ANCAR INCORPORATES WHAT WE HAVE CALLED "Touch Expert".

■ Our interpretation of how technology gives professionals new experiences and applications to make their work more precise, safer and more dynamic. Touch technology is constantly taking over in any area of our society thanks to its great simplicity,

ease and reliability. The interaction, the dialogue between machine and user, its versatility and durability makes this technology ideal for maximum performance from your dental unit. "Touch Expert" is Ancar's offer to give professionals greater performance, maximum precision and informative details verging on perfection. With the New Series 5 "Touch Expert" from Ancar you will enjoy a new experience that is as practical, simple and intuitive as it is profitable ■



Simple, Dynamic and clear screen: Easy and Intuitive.



Personalise your unit with 4 different users.



Programme the instruments to your standard settings.



Asses the work pace. Statistics on the unit's use.



Maximize the features of your micromotor. Torque control in Ncm, direct or reverse rotation.



Setting the working parameters of each instrument.

NEW

NEW STIMULATING DESIGNS AND INNOVATIONS
LOOKING FOR PRACTICALITY, SIMPLICITY AND
DURABILITY.

■ The innovative power and Ancar's continuous improvement in every area of the dental unit, makes it better in ergonomics, hygiene and safety, in order to have a comfortable, safe and reliable intervention ■



Cannulas arm with adjustable height (3 positions).



Narrow backrest (optional).



Customized water box made of anti-corrosive aluminium.



Wireless Foot Pedal (optional).



Multi-position articulated and ergonomic headrest for children and adults.



Optional auxiliary tray. Working surface dimensions: 400 x 300 mm.

Sd-550

Touch Expert

Electronic
treatment unit
(Whip arm delivery
system)



FEEL COMFORTABLE, WORK AT EASE

■ The principle behind the New Series 5 is comfort and ergonomics. Comfort and working ergonomics for doctor and assistant with total freedom for more natural movement and maximum flexibility in work positions.

The new Series 5 has been conceived to make your interventions simpler, more agile and effective. The suspended chair improves working accessibility, with an elevation range of between 380 and 800 mm for working sitting or standing ■

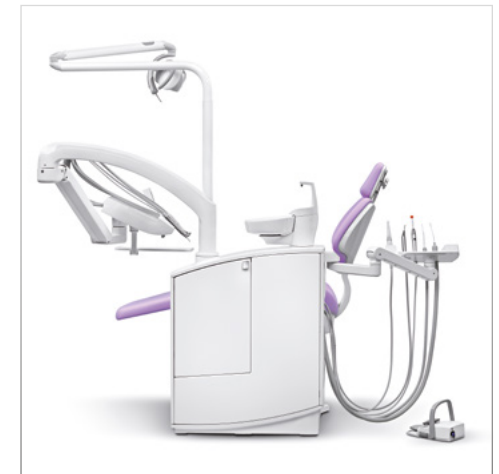

Large capacity water unit with door for easy access.

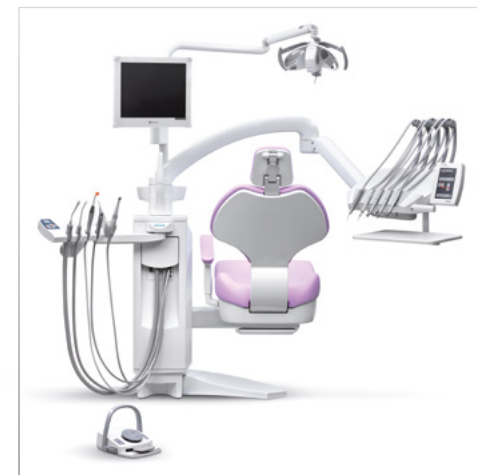

Easy access to the instrument tray and auxiliary support from the work position.

Sd-575

Touch Expert

Electronic
treatment unit

Hanging hose system



NEW VERSIONS, MAXIMUM PERFORMANCE.

■ The Sd-575 features the hanging hose system offering the traditional style delivery unit with flexible positioning for different working styles.

Greater performance for top level treatments and intuitive, programmable handling of the instruments according to the specific conditions of each instrument ■

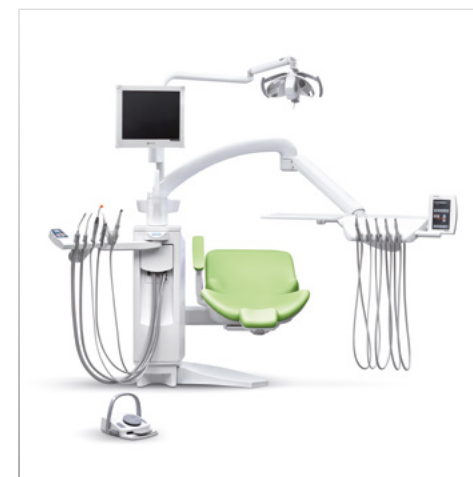

Rear view in working position.

MAXIMUM ADAPTABILITY, INFINITE POSSIBILITIES.



Sd-580

Touch Expert

Electronic
treatment unit
Unit + cart





ONE MODEL FOR MULTIPLE USES.

■ Effectively the Sd-580 Touch Expert is the ideal solution for queries involving different professionals, or users used to working with the independent mobile cart system.

Its innovative and robust design and the total integration of the digital technology with its service makes this model an innovative, reliable unit that is highly versatile for any kind of clinic ■



DETAILS
THAT
MAKE THE
DIFFERENCE

THE QUALITY IS ALSO INSIDE



ALUMINIUM CORE



Integrated USB port as standard.
Auxiliary air, water and 220 V sockets for peripheral instruments.



Removable and autoclavable instrument support.



Made in light, anticorrosive aluminium alloy.



Selective system of aspiration hoses. Quick connections: USB 2.0 port built + air/water intake + output.



Robust build quality and cutting-edge technology.



Wide range of elevation from 380 to 800 mm.
For sitting and standing interventions.

DETAILS
THAT
MAKE THE
DIFFERENCE

WIRELESS FOOT PEDAL AS STANDARD

Up and down chair and backrest movements.

Safety activation handle.

Micromotor rotation inversion.

Selection of "chip-blower". Short air blow.

Selection of air-water-spray instrument.

Automatic return to zero with one touch.

Start up and instrument accelerator lever. Increasing proportionality from left to right.

DOUBLE SECURITY:
While the pedal is operating, the chair movements are blocked. Lock chair movements by using the "joystick" pedal.

Signal and battery indication in the *Touch Expert* screen.

Optional wireless pedal with long battery use and possibility to use whilst charging.

NEW WATER BOX: ELEGANT, HYGIENIC AND FUNCTIONAL



Large capacity water box.



Easy access door to the suction and disinfection systems.



Porcelain cuspidor bowl, manually revolving and built-in turning safety.



Removable, self-fixing spittoon bowl.



Removable cup filler for easier cleaning.

PERSONALISE
THE UNIT TO
SUIT YOU

DISINFECTION SYSTEMS AND AMALGAM RECOVER

WEK WEK Light DENTA PURE



WEK water decontamination system for instrument hoses. Combined, automatic water circuit decontaminating cycles in rotating instruments. Non-toxic, continuous and effective decontaminating effect. Automatic supervision of sterilized dosing. Maintenance-free operation.

TYPE 1 CAS-1 COMPACT DYNAMIC



Built-in amalgam recovery and air and water separation systems with selection valve: dry or wet suction.



H1 System of continuous cleaning and complete disinfection of the suction system. Without need for additional manual disinfection. H1 includes the S1 automatic suction hose selection system.

LAMPS

The new generation of high-specification lamps with LED technology offer a whole range of benefits:

- LED lights generate a natural quality light which guarantees sharper vision in comparison with halogen light since they offer a greater visual field, fewer shadows during the treatment process and a whiter cold light.
- LED light sources are longer lasting than the halogen bulbs; with minimum heat generated and lower consumption.



TECHNICAL FEATURES	ALYA	THEIA TECH*	MAIA	POLARIS	C-200
Light source	2 LED's	2 LED's	2 LED's	10 LED's	6 LED's
Colour temperature (°K)	5.000 K	5.000 K	5.000 K	de 4.200 K a 5.800 K	4.800 K
Light intensity (lux)	de 3.000 a 50.000 lux	de 3.000 a 50.000 lux	de 3.000 a 35.000 lux	de 8.000 a 35.000 lux	30.000 lux
Colour rendering index (CRI)	95	95	85	→ 85	92
Illuminated area (mm)	180 x 90	180 x 90	170 x 85	140 x 70	150 x 80
Power supply	17-24 vac 50/60 hz	24 vac 50/60 hz	17-24 vac 50/60 hz	12-24 vac 50/60 hz	10-18 vac 50/60 hz
Consumption	26 VA	44 VA	9 VA	29 VA	14 W
Guarantee	24 months	24 months	12 months	24 months	24 months
Certificate according to directive	93/42 CE class I	93/42 CE class I	93/42 CE class I	93/42 CE class I	93/42 CE class I

* THEIATECH is the innovative LED lighting system which enhances the view range of the pre-operative area, through a lighting balance inside the dental practice in order to reduce the doctor's visual stress. THEIATECH light source consist of 54 LEDs which, through a dedicate diffuser, distribute a cone of light that spreads into the surrounding environment, preventing the glare created by the sudden change of light. THEIA TECH has two light sources: operative area with 2 LED adjustable from 3.000 to 50.000 Lux and pre-operative area with 54 LED adjustable from 800 to 1.500 Lux.

PERSONALISE
THE UNIT TO
SUIT YOU

IMAGING SYSTEMS

LCD monitor 17" to 24", high resolution (1280 x 1024). Lasting screen, versatile and high output display with a wide range of integrated video options, designed specifically for dentistry environments. Anti-glare optical crystal. Metal housing.



'Faro' Monitor Mount with side and vertical rotation.

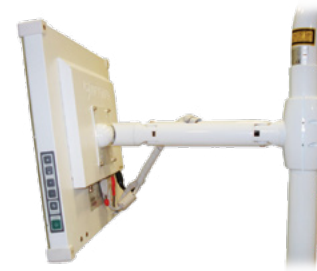

'Start' Monitor Mount.

Wide range of intraoral cameras with integrated systems, ideal for training and motivate patients in all treatment phases. Clear and simple images for immediate use.

BRUSH-FREE INDUCTION MICRO MOTOR

Brushless induction Micromotor with ENDO functions. Programable for contra angle ration, minimum and maximum speed, par, torque, forward/reverse and optic light intensity. High benefits at high and low speed (from 100 to 40.000 rpm), which allows a wide range of interventions:

- High speed for restoration work.
- Low speed (100 - 4000 rpm) for endodontic.
- Automatic reverse rotation when the selected par is reached.

- Automatic return to counter clockwise (adjustable time delay).
- Autoclavable.
- Light, powerful and quiet.
- Virtually no maintenance.
- Long working life.
- Non-vibrating.

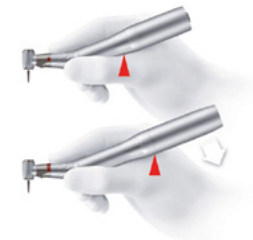

AUXILIARY TRAYS



Double standard auxiliary tray (410 x 310 mm).



Big auxiliary tray (350 x 230 mm).



Small auxiliary tray (285 x 190 mm).

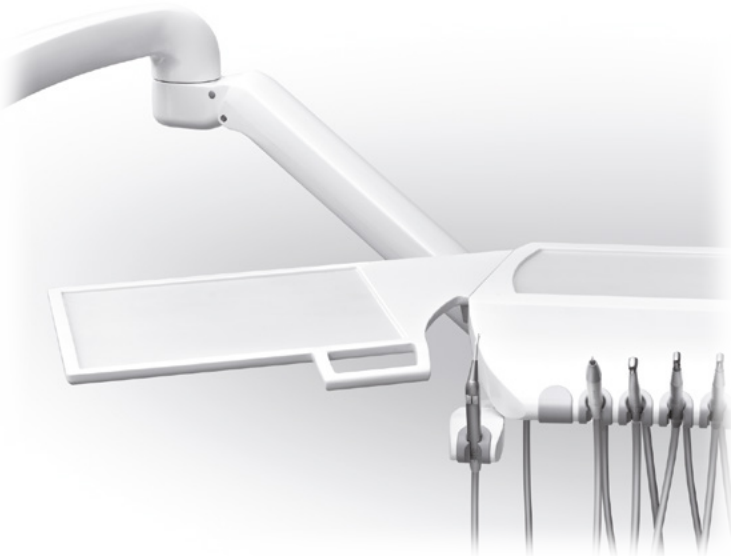

Auxiliary tray (400 x 300 mm) "For hanging hose version". Additional syringe support is included.



Auxiliary tray "Faro" (405 x 365 mm).

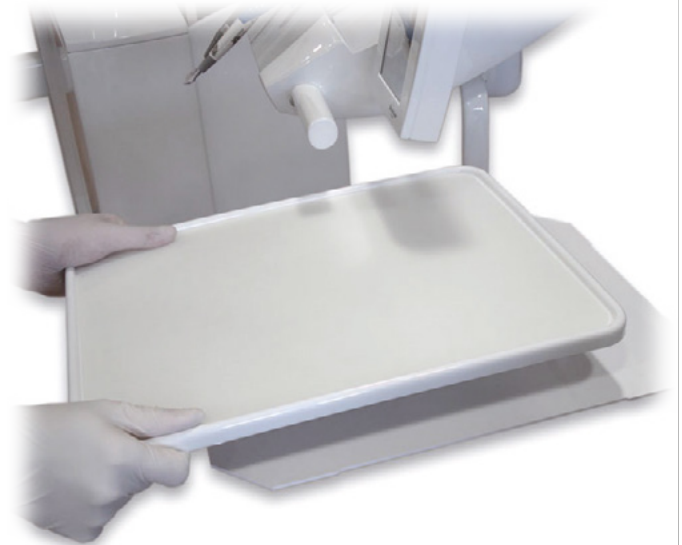

Tray holder, removable and with silicone protection.

BACKRESTS

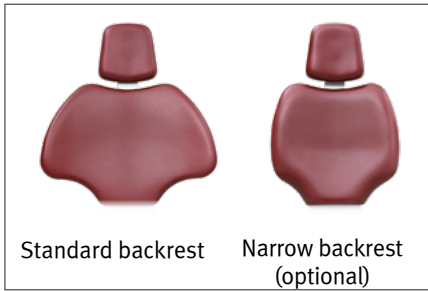

OPTIONAL RIGHT-SIDE ARM



STOOLS



HEADREST AND BACKREST



CUSPIDOR COVER COLOURS



STANDARD RANGE UPHOLSTERY COLOURS

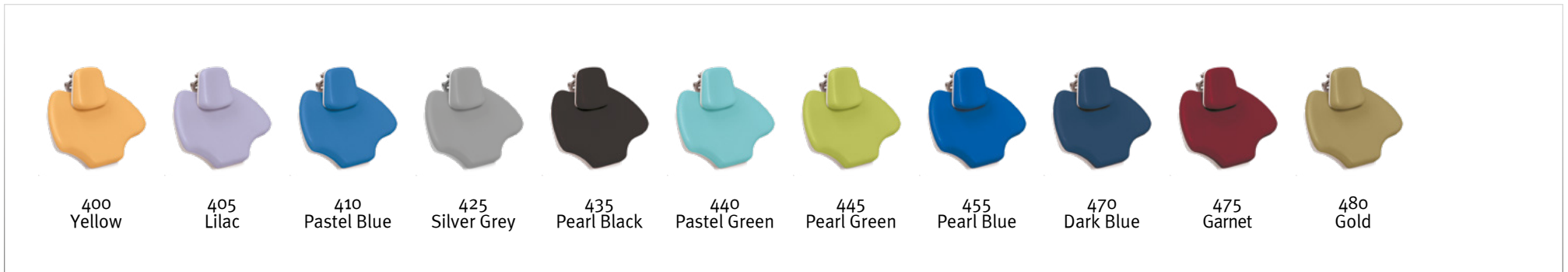

'SOFT PLUS' UPHOLSTERY COLOURS



TECHNICAL FEATURES

FUNCTIONALITY

- Chair vertically suspended and raised to improve accessibility to the patient, with a lifting range from 380 to 800 mm to work standing or seated.
- Connection box built into the water unit.
- Up to 8 instruments: 5 in the main tray and 3 in the auxiliary support.
- Multifunctional and proportional electronic pedal with water selection, micromotor reverse turn, “Chip blower function” and unit movements.
- Auxiliary tray (310 x 410 mm) for small hand-instruments.
- Possibility of turbine and micromotor (M40) interchange in the same hose.
- Automatic ON/OFF lamp in rest and return to cuspidor position.
- Individual water flow regulation for each instrument.
- Quick connection Kit: USB 2.0 port built + air/water intake + output 230 V. installed as standard.
- ON/OFF supplying water and air to the unit.
- Programmable torch effect in selecting instruments with light.
- Syringe 6F. Stainless steel installed as standard.

PROGRAMMING

- Electronic unit controlled by microprocessor with “Touch Expert” display.
- “Autotest” of the unit at start up.
- Identification of the dental centre, date and time.
- Programming for 4 different users and configuration of instruments for each one.
- Programming of ultrasound work parameters in ENDO, PERIO, SCALER, work range, and instrument light intensity.
- Adjustment of micromotor work parameters (with ENDO functions): torque control in Ncm, direct or reverse rotation, irrigation mode (spray/water), type of counter-angle and two types of speed: from 200 to 40,000 rpm and from 100 to 4,000 rpm.
- Graphic display of ultrasound power level and real turbine working speed.
- Statistics of the use of the unit: chair movements, instrument use, frequent warnings and recent warnings.
- System for detecting and controlling faults or warnings.
- Choice of language for working.
- Countdown function.
- Electronic adjustment of the cup water filling time and spittoon bowl flush with combined or individual setup.
- “Update Device” system: includes the latest programming updates even years after purchase.
- “Chip-blower” automatic programming.

ERGONOMICS

- Electrically – operated chair with trendelenburg and 5 position memories (three for working, reset and return to cuspidor).
- Diaphanous, obstacle-free space under the chair increasing work positions for dentist and assistants.
- Multi – position articulated head with minimum height of 380 mm, facilitating treatments in the upper pieces.
- Manually revolving spittoon bowl tray adaptable to the patient’s distance.
- Chair movements available on control pedal and keypad (principle and assistant).
- Arm and instrument tray with mechanical compensation and pneumatic brake: better handling with less effort.
- Optional right-side arm turning through 180°.
- Cannulas arm with adjustable height (3 positions).
- Ergonomic headrest at the same level as the optional backrest.
- Optional tight backrest.

SAFETY FEATURES

- In support of auxiliary cannula, back and lower part of the chair.
- In the chair upholstery when getting off.
- Of movements by main and auxiliary keyboard.
- On optional instruments (turbine, micromotor and ultrasound) through adjustor pedal.
- In choosing a second instrument.
- In turning spittoon bowl.
- Unit manufactured according to the Medical Devices Directive 93/42/EEC, which design and construction meet applicable safety requirements of dental product regulations and IEC standards.

HYGIENE

- Removable and autoclavable silicone instrument mat.
- Standard suction hoses removable and thermo disinfected.
- Easy-clean suction filter.
- Removable spittoon bowl tray self-fixing at 135°.
- Removable cup filler for easy cleaning.
- Rotary instrument oil recuperator.
- Designed for easy cleaning and disinfection.
- “WEK” optional system for decontaminating water in instrument hoses.
- Optional “H1” system for disinfecting suction hoses.
- Amalgam separation for wet or dry suction systems.

MATERIALS

- ALUMINIUM CORE: Unit, chair and pedal manufactured in light anti-corrosive aluminium alloy.
- Porcelain cuspidor bowl.
- “Standard” and “Soft drive” upholstery, high quality and hygienic, fireproof, steam and air permeable, highly elastic and pleasant feel.



DIMENSIONS

Sd-550 Touch Expert

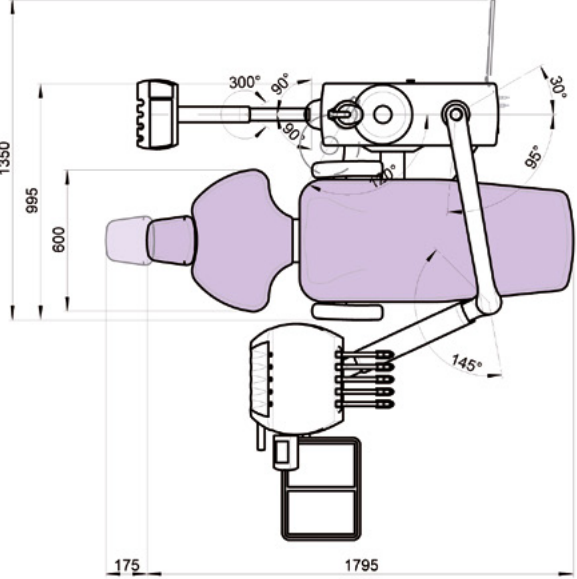
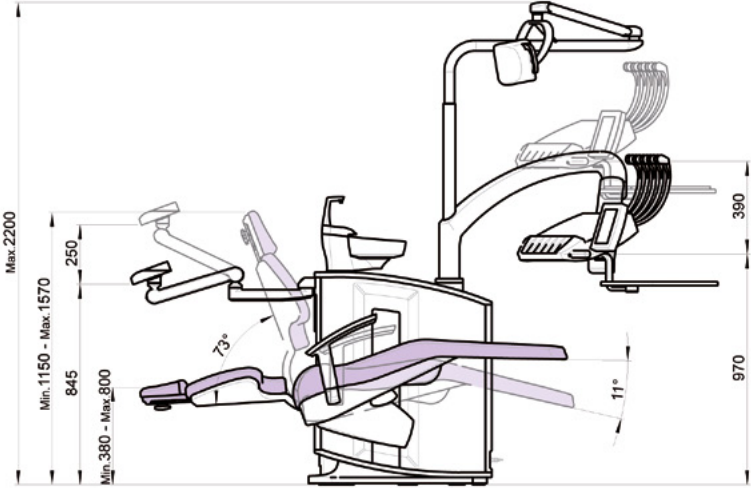

Sd-575 Touch Expert

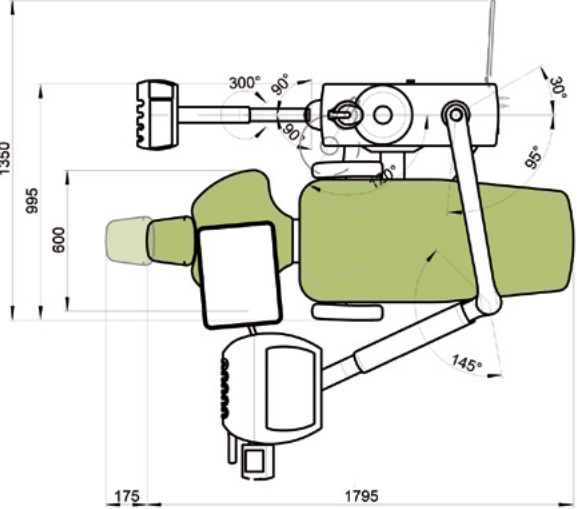
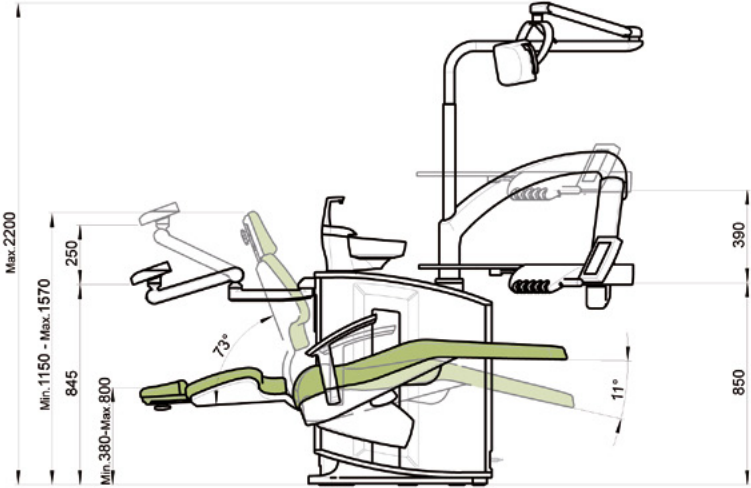

Sd-580 Touch Expert

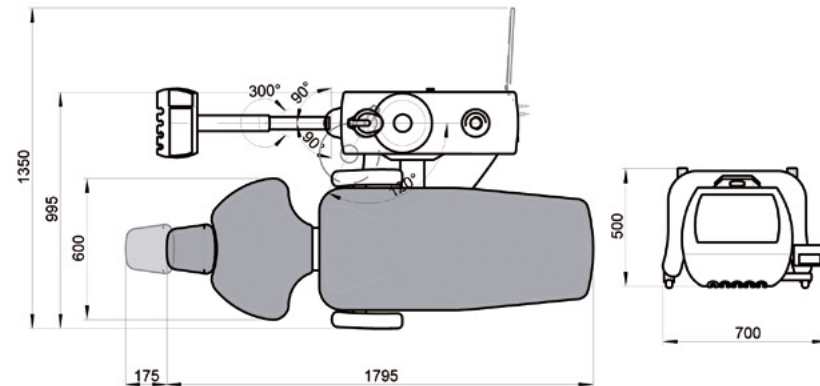
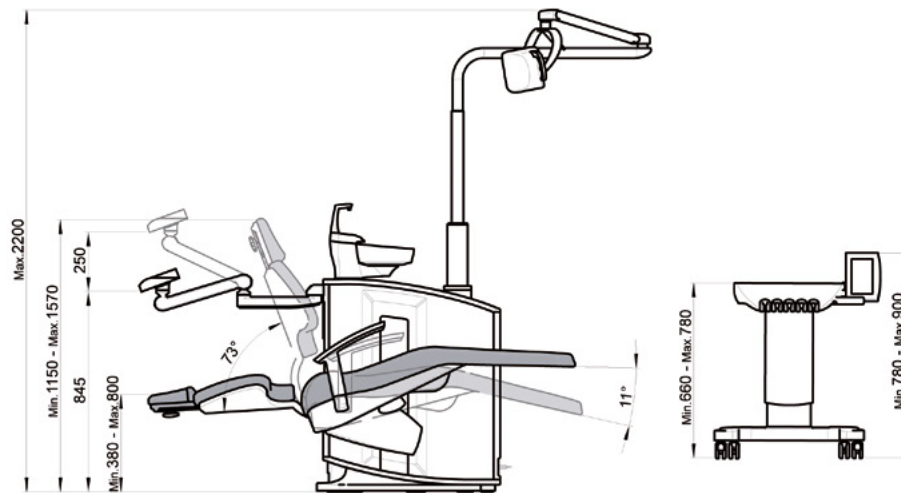

TECHNICAL DATA

Voltage	220 - 240 V~	93/42/EEC type unit	Class IIa
Frequency	50 Hz	Type of insulation	Type BF
Air pressure	5,5 Bar	Net / Gross weight of the unit	335 kg / 385 kg
Water pressure	3 Bar	Type of dental unit	Electronic
Power	1200 W	Type of installation	Permanent
Electrical protection type	I	Main fuse	T 6.3 A / 250 V
Type of operation	Intermittent	Movement chart fuse, 24 V line	T 32 mA / 250 V
Maximum load (patient)	160 kg	Primary transform fuse, 9015093 PCB	TT 2.5 A / 250 V
Maximum tray instrument-holder load	2 kg	1st power line 24 V ac (yellow/blue)	Polyswitch RUE400
Electric micro-motor instrument	24 Vdc / 65 W	2nd power line 24 V ac (blue/Brown)	Polyswitch RUE400 + RUE600
Mx micro-motor instrument	24 Vdc / 60 W (130 W pico)	17 V ac protection (red/red)	Polyswitch RUE600 + RUE185
Light instruments	3V - 7V / 2.5 W	24 V ac auxiliary outputs	4 x water box
Ultrasound	24 Vac / 35 W	Suction connection	3 x instrument tray
Polymerization lamp	24 Vac / 150 W	AUX contact connections chart free power	1 x circuit box
6F syringe	24 Vac / 150 W	230 V ac auxiliary output	500 W / 230 V Relays 20 A / 250 V
		Main electro-valves	Max 250 V / 5 A
			50 W
			24 Vdc



WE CARE ABOUT YOU

www.ancar-online.com



Check conditions with
the official distributor.



QS4 LEA o88. V1

Subject to design and/or specifications changes without prior notice. Made in Europe. 6th Edition January 2018.

Antoni Carles, S.A.
Volta dels Garrofers, 41-42 Polígono Industrial "Els Garrofers"
08340 Vilassar de Mar (Barcelona-SPAIN)
Tel. (34) 93 754 07 97 Fax (34) 93 759 26 04
www.ancar-online.com / e-mail: ancar@ancar-online.com