

Series 3

Touch Expert





MANUFACTURING TRADITION SINCE 1958.

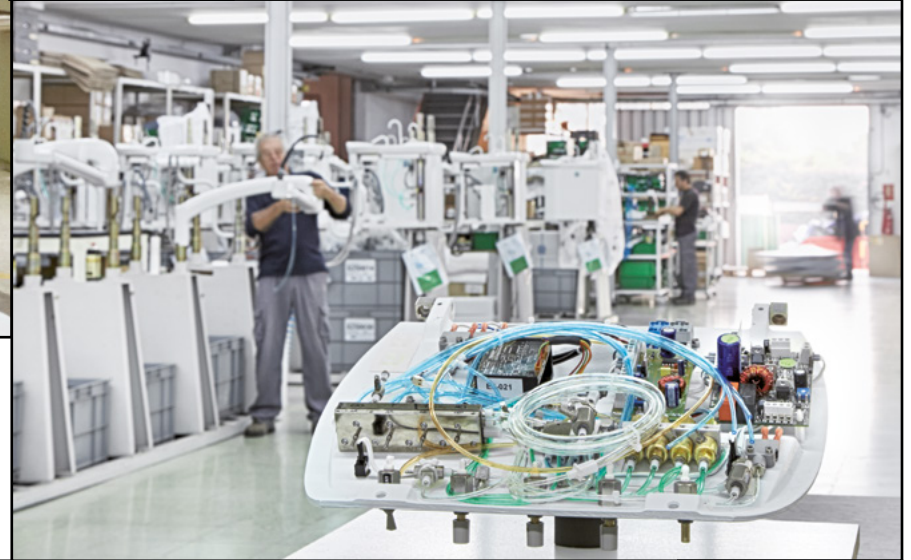

TECHNOLOGY, SERVICE AND ENGAGEMENT.

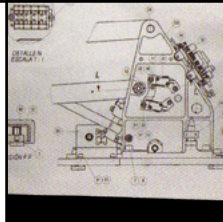



WELCOME TO ANCAR

■ In 1988, when we presented the Pyrinee model, our first dental unit and at the time the only model produced by Ancar, we could not have predicted, or even imagined, the impressive growth and recognition that the brand would have at the international level 30 years later.

In fact, it has not been easy to get here, but with a lot of determination, peace of mind and humility we have managed to forge a space and earn recognition in an extremely demanding and competitive market, while at the same time establishing the foundations of a consolidated and highly valued brand in 32 countries from Europe, the Middle East, Oceania and the Maghreb.

Since 1958, the passion for creation, innovation and design have been the basic elements of our activity, with the goal of offering professionals from the sector the highest quality, most durable and best performing treatment units.

Today more than 40 different models make up our range, all of them manufactured with aluminium. Ergonomic, technological and reliable solutions form the perfect base to develop a range of high performance dental units, with long-lasting quality and impeccable output.

Ancar's success over these nearly 60 years of history does not belong to one person or another: it belongs to everyone! Only true, honest and professional team work is capable of explaining our experience and ensuring our future.

“This is our history,
this is our philosophy,
this is our commitment”.

Antoni Carles Bosch
General Manager



Antoni Carles Pujol
President



Antoni Carles Bosch
General Manager

Series 3

Touch Expert



The new Ancar Series 3,

electronic treatment centre, represents the culmination of our extensive experience in the dentistry world.

A flawless design and the planned and an audited construction are meant to last, thereby it is the proven and current touch technology innovation.

Our interpretation of how machine-user interaction should be. A new experience that makes your work more intuitive, precise, safe, dynamic and profitable.

'Touching technology' is Ancar's promise to offer professionals more benefits, maximum precision and informative details with a perfection of quality.



Sd-300 *Touch Expert*

Electronic treatment centre
(Whip arm delivery system)



Sd-350 *Touch Expert*

Electronic treatment centre
(Hanging hose delivery system)



Sd-80 *Touch Expert*

Electronic treatment centre
(Unit + Cd-80 *Touch Expert* Mobile delivery cart)

Simple
Smart
Solid

TECHNOLOGY

Touch Expert

THE TREATMENT CENTRES IN THE ANCAR 3 SERIES INCORPORATE WHAT WE CALL "Touch Expert".

■ Our interpretation of how technology provides the dental professional with new systems and facilities to make their work more precise, safe and dynamic. Every day, touch technology is gaining more and more ground in our society thanks to its great simplicity, ease and reliability.

The interaction, the dialogue between machine and user, its versatility and its durability make this technology ideal for getting the maximum performance from your dental unit. "Touch Expert" is Ancar commitment to offer the professional greater features, maximum precision and informative details that come close to perfection. With the "Touch Expert" 3 Series by Ancar, you will enjoy a new experience that is as practical, simple and intuitive as it is profitable ■



Simple, dynamic and clear screen: easy and intuitive to use.



Personalise your unit with 4 different users.



Programme the instruments to your standard settings.



Asses the work pace. Statistics on the unit's use.



Maximize the features of your micromotor. Torque control in Ncm, direct or reverse rotation.



Setting the working parameters of each instrument.

NEW

NEW STIMULATING DESIGNS AND INNOVATIONS
LOOKING FOR PRACTICALITY, SIMPLICITY AND
DURABILITY.

■ The innovative power and continuous improvement of Ancar in all the dental unit areas, improve in ergonomics, hygiene, security..., to develop the intervention in an exceptionally comfortable, secure and reliable way ■



Cannulas arm with adjustable height (3 positions).



Selective system of aspiration hoses.



Water box made of anti-corrosive aluminium.



Wireless Foot Pedal (optional).



Multi-position articulated and ergonomic headrest for children and adults.



Optional auxiliary tray. Working surface dimensions: 400 x 300 mm.

Sd-300

Touch Expert

Electronic
treatment centre
(Whip arm delivery
system)



PROVEN RELIABILITY.

■ The whole of the Ancar range features the security of optimum operation. In modern dentistry, patients and professionals need to know at all times that they are in “safe hands”.

Besides being designed under efficient parameters of sturdiness and ergonomics, the Sd-300 Touch Expert predicts and controls any errors that may interrupt the professional’s normal working process. Its “Check Control” electronic safety system checks on start-up that all functions are optimally available to undertake any action in perfect instrumental conditions ■



Auxiliary cannula support with two aspiration hoses installed as standard. Possibility of installing optional 6F inox syringe, polymerize lamp and intraoral camera.



Sd-350

Touch Expert

Electronic
treatment centre
(Hanging hose
delivery system)





Auxiliary standard tray (285 x 190 mm).



Water box with 70° turn. Facilitates the assistant a comfortable and closer to patient access.

PRECISION IN EVERY DETAIL.

■ The Ancar 3 Series represents the culmination of a well done job. Added to a perfect design, the result of our extensive experience and the planned and audited construction are meant to last, thereby it is all the innovation that today's technology offer us.

In line with this philosophy, the Sd-350 Touch Expert offers dentistry professionals the maximum aspiration in work comfort, patient well-being and precision in actions with the peace of mind of an approved and tested reliability.

Design the layout of the instrument to suit you, with 5 positions in the main tray and 3 for the assistant: modular programmable and expandable ■



Optional Auxiliary tray for traditional hoses system.
Surface work dimensions:
400 x 300 mm.

● Includes support for additional syringe.

Sd-80

Touch Expert

Electronic
treatment centre.

Unit + Cd-80
Touch Expert

Mobile delivery cart



PURE TECHNOLOGY = MAXIMUM PERFORMANCE.

■ With the Sd-80 Touch Expert unit, any consultation offers your patients the most avant-garde design, features and technology.

Your ability to communicate with the patient is maximized by integrating an LCD touch screen. That way you use pictures to reinforce the details of any information, leading you a new kind of doctor-patient interaction which strengthens the relationship.

The Sd-80 dental unit offers a great deal of versatility and enables you to find usable work spaces where other units would not fit. An infallible formula to find the right and relaxed operative configuration every time ■



ancar

WE CARE ABOUT YOU

www.ancar-online.com

DETAILS
THAT
MAKE THE
DIFFERENCE

THE QUALITY IS ALSO INSIDE

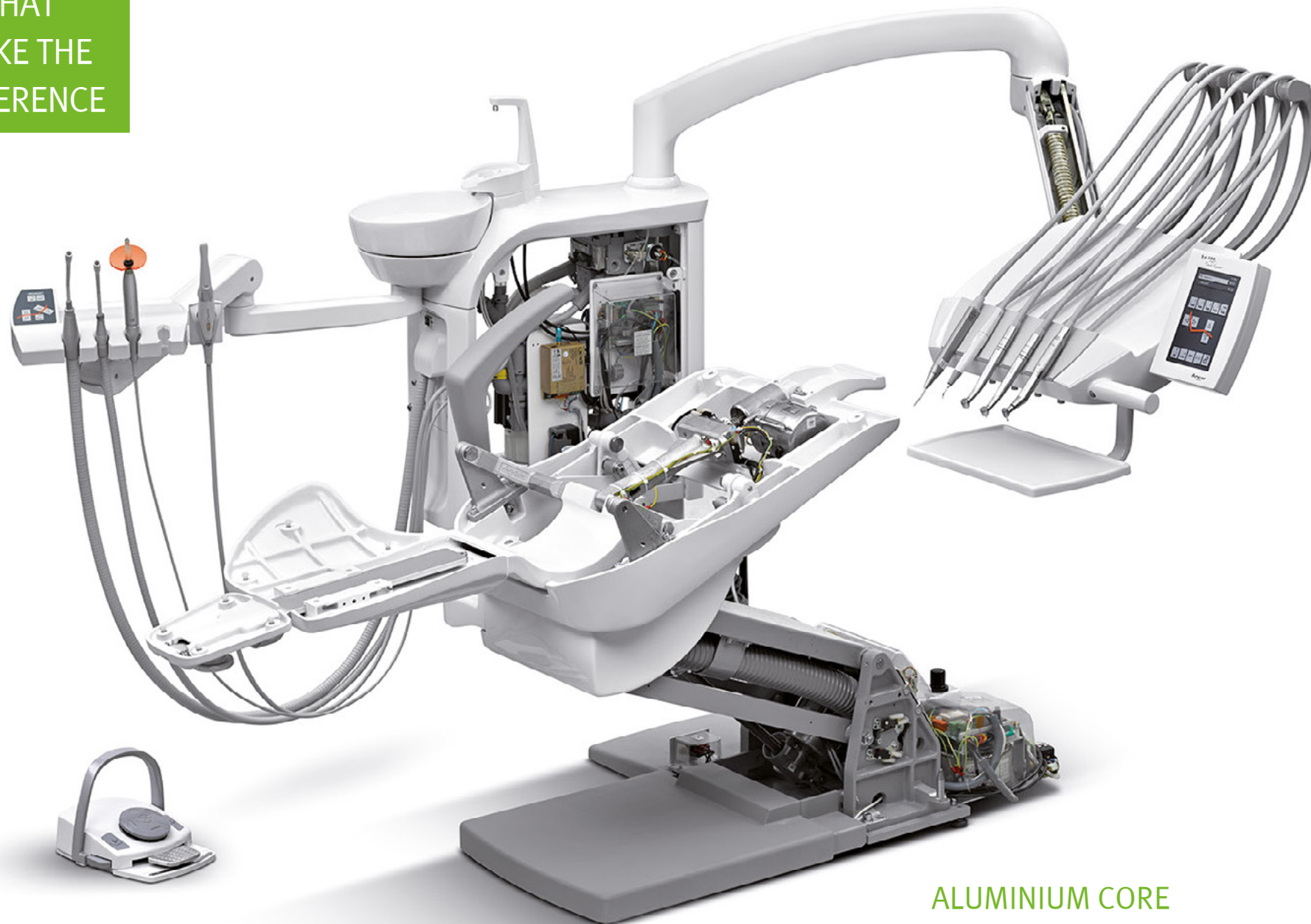

ALUMINIUM CORE

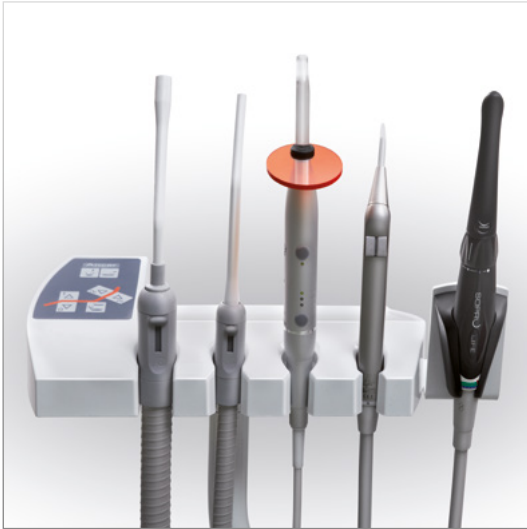

Assistant support with two aspiration hoses installed as standard. Possibility of installing 6F. Inox Syringe; polymerize lamp and intraoral camera.



Removable and autoclavable instruments support.



Made in light, anticorrosive aluminium alloy.



Rotary instrument oil collector.



Robust build quality and cutting-edge technology.



Excellence in constructive details.

PERSONALIZE
THE UNIT TO
SUIT YOU

WIRELESS FOOT PEDAL (OPTIONAL)

Up and down chair and backrest movements.

Safety activation handle.

Micromotor rotation inversion.

Selection of "chip-blower". Short air blow.

Selection of air-water-spray instrument.

Automatic return to zero with a simple pulsation.

Start up and instrument accelerator lever. Increasing proportionality from left to right.

DOUBLE SECURITY:
While the pedal is operating, the chair movements are blocked. Lock chair movements by using the "joystick" pedal.

PEDAL WITH STANDARD CABLE

Electronic pedal with vertical activation for working with/without water, micromotor direction inverter, "chip blower" drive and chair movement.

Signal and battery indication on screen.

Optional wireless pedal with long battery possibility to use whilst charging .

LAMPS

The new generation of high-specification lamps with LED technology offer a whole range of benefits:

- LED lights generate a natural quality light which guarantees sharper vision in comparison with halogen light since they offer a greater visual field, fewer shadows during the treatment process and a whiter cold light.
- LED light sources are longer lasting than the halogen bulbs; with minimum heat generated and lower consumption.



| TECHNICAL FEATURES | ALYA | THEIA TECH* | MAIA | POLARIS | C-200 |
|------------------------------------|-----------------------|-----------------------|-----------------------|-----------------------|--------------------|
| Light source | 2 LED's | 2 LED's | 2 LED's | 10 LED's | 6 LED's |
| Colour temperature (°K) | 5.000 K | 5.000 K | 5.000 K | de 4.200 K a 5.800 K | 4.800 K |
| Light intensity (lux) | de 3.000 a 50.000 lux | de 3.000 a 50.000 lux | de 3.000 a 35.000 lux | de 8.000 a 35.000 lux | 30.000 lux |
| Colour rendering index (CRI) | 95 | 95 | 85 | → 85 | 92 |
| Illuminated area (mm) | 180 x 90 | 180 x 90 | 170 x 85 | 140 x 70 | 150 x 80 |
| Power supply | 17-24 vac 50/60 hz | 24 vac 50/60 hz | 17-24 vac 50/60 hz | 12-24 vac 50/60 hz | 10-18 vac 50/60 hz |
| Consumption | 26 VA | 44 VA | 9 VA | 29 VA | 14 W |
| Guarantee | 24 months | 24 months | 12 months | 24 months | 24 months |
| Certificate according to directive | 93/42 CE class I | 93/42 CE class I | 93/42 CE class I | 93/42 CE class I | 93/42 CE class I |

* THEIATECH is the innovative LED lighting system which enhances the view range of the pre-operative area, through a lighting balance inside the dental practice in order to reduce the doctor's visual stress. THEIATECH light source consist of 54 LEDs which, through a dedicate diffuser, distribute a cone of light that spreads into the surrounding environment, preventing the glare created by the sudden change of light. THEIA TECH has two light sources: operative area with 2 LED adjustable from 3.000 to 50.000 Lux and pre-operative area with 54 LED adjustable from 800 to 1.500 Lux.

PERSONALIZE
THE UNIT TO
SUIT YOU

NEW WATER BOX: ELEGANT, HYGIENIC AND FUNCTIONAL



Removable and autoclavable porcelain cuspidor bowl.



Removable cup filler for an easier cleaning.

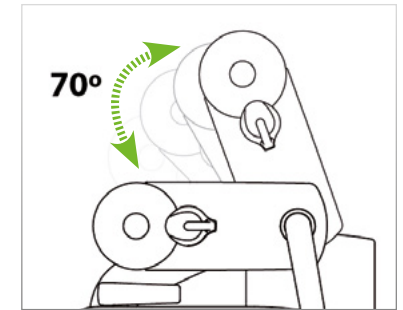

70° turn for access to the left of the patient and additional working space for the assistant.



Selective system of activation hoses. Quick connections: usb 2.0 port build + air/water intake + output.



'Touch Open' door giving easy access inside the cuspidor.

DISINFECTION SYSTEMS AND AMALGAM SRECOVERY



WEK water decontamination system for instrument hoses. Combined, automatic water circuit decontaminating cycles in rotating instruments. Non-toxic, continuous and effective decontaminating effect. Automatic supervision of sterilized dosing. Maintenance-free operation.

H1 system of continuous cleaning and complete disinfection. H1 includes automatic suction hose selection system.

Built-in amalgam recovery and air and water separation systems with selection valve: dry or wet suction.

NEW “SELF WATER SYSTEM”



- Independent water supply system for instruments on the equipment.
- The equipment water circuit is designed in order to prevent water returns due to a loss of pressure. Thereby avoiding, the mixture of different water uses, discarding any cross contamination to the public water supply and vice versa.
- This system ensures compliance with regulations EN1717.

PERSONALIZE
THE UNIT TO
SUIT YOU

IMAGING SYSTEMS

LCD monitor 17" to 24", high resolution (1280 x 1024). Lasting screen, versatile and high output display with a wide range of integrated video options, designed specifically for dentistry environments. Anti-glare optical crystal. Metal housing.

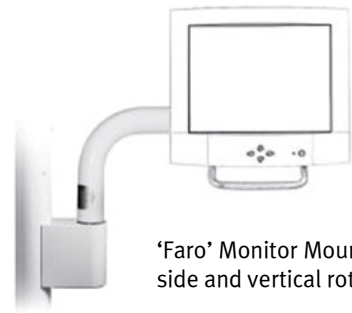

'Faro' Monitor Mount with side and vertical rotation.

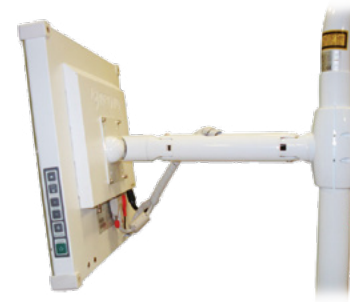

'Start' Monitor Mount.

Wide range of intraoral cameras with integrated systems, ideal for training and motivate patients in all treatment phases. Clear and simple images for immediate use.

BRUSH-FREE INDUCTION MICRO MOTOR

Brushless induction and ENDO functions micromotor. It programs type contra angle, the minimum and maximum speed, par, torque, direction of rotation and micromotor light intensity. High benefits at high and low speed (from 100 to 40.000 rpm), which allows a wide range of interventions:

- High speed for restoration work.
- Low speed (100 - 4000 rpm) for endodontic.
- Automatic reverse rotation when the selected par is reached.

- Automatic return to counter clockwise (adjustable time delay).
- Autoclavable.
- Lighter, powerful and quiet body.
- Virtually no maintenance.
- Long working life.
- Non-vibrating.



AUXILIARY TRAYS

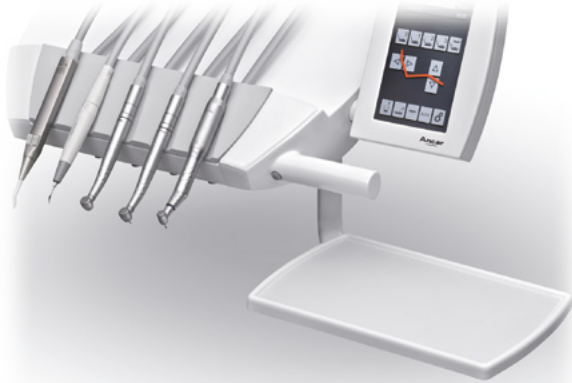

Standard auxiliary tray (285 x 190 mm).



Big auxiliary tray (350 x 230 mm).



Double auxiliary tray (410 x 310 mm).

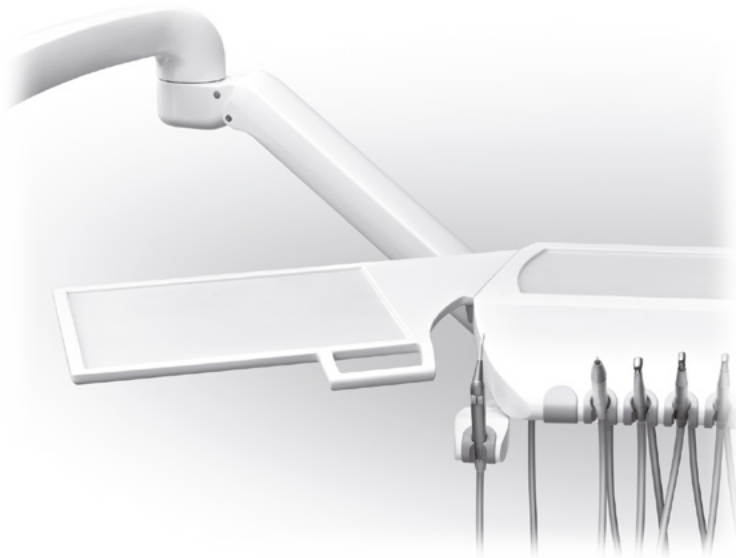

Auxiliary tray (400 x 300 mm) "For hanging hose version".
Additional syringe support is included.



Auxiliary tray "Faro" (405 x 365 mm).

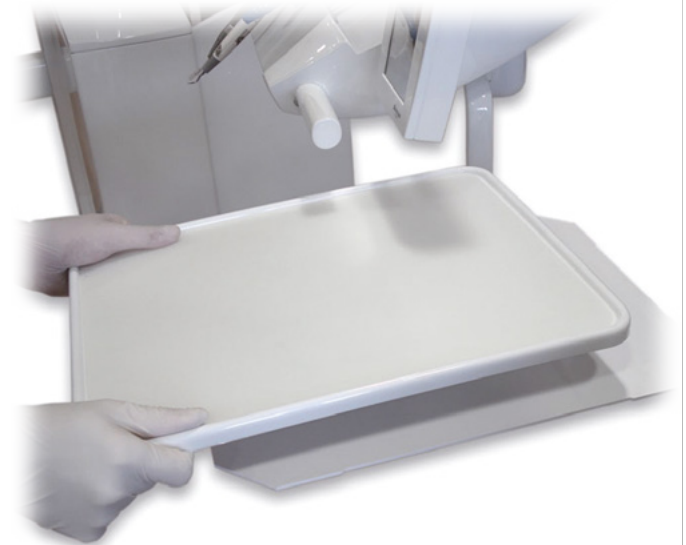

Tray holder, removable and with silicone protection.

BACKRESTS

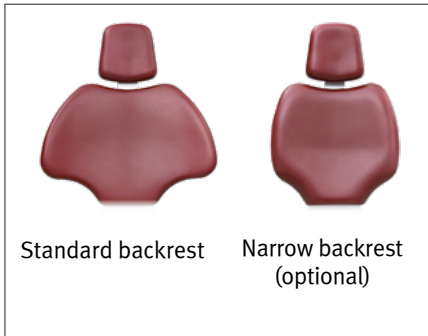

OPTIONAL RIGHT-SIDE ARM

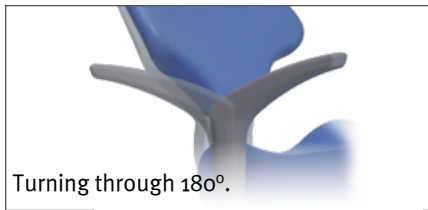

STOOLS



HEADREST AND BACKREST

Multifunctional articulated headrest



Ergonomic headrest with spherical movement and pneumatic brake or hand brake (optional)



Axle path 170 mm

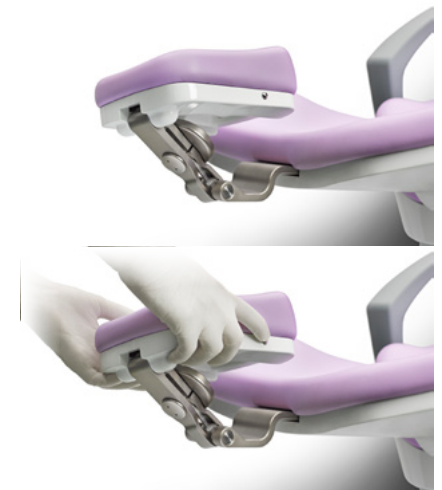

CUSPIDOR COVER COLOURS



STANDARD RANGE UPHOLSTERY COLOURS

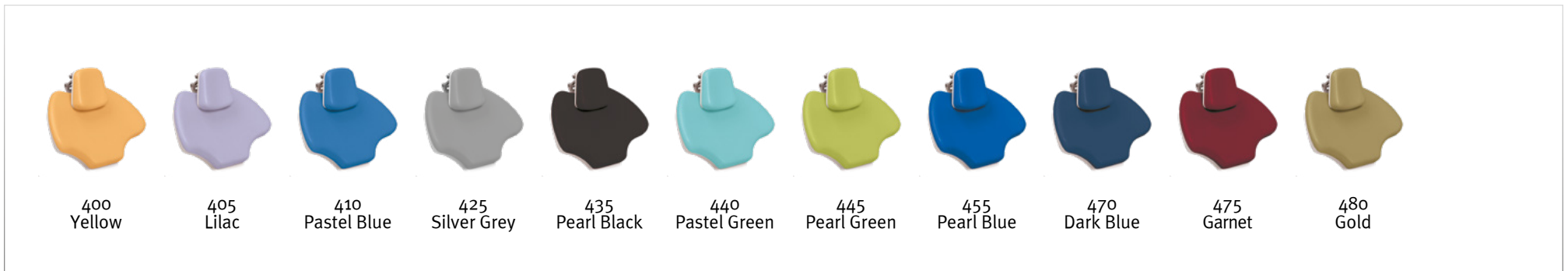

“SOFT PLUS” UPHOLSTERY COLOURS



TECHNICAL FEATURES

FUNCTIONS

- Unit with an elevation range from 400 to 810 to work while sitting or standing.
- Connections box in the unit base.
- Up to 8 instruments: 5 in the main tray and 3 in the assistant's tray.
- Multifunctional and proportional electronic pedal with water selection, micromotor reverse turn, "Chip blower function" and unit movements.
- Auxiliary tray (285 x 190 mm) for small hand-instruments.
- Possibility of turbine and micromotor (M40) interchange in the same hose.
- Automatic ON/OFF lamp in rest and return to cuspidor position.
- Individual water flow regulation for each instrument.
- Quick connection Kit: USB 2.0 port built + air/water intake + output 230 V. installed as standard.
- ON/OFF supplying water and air to the unit.
- Programmable torch effect in selecting instruments with light.
- Syringe 6F. Stainless steel installed as standard.

PROGRAMMING

- Electronic unit controlled by microprocessor with "Touch Expert" display.
- "Autotest" of the unit at start up.
- Identification of the dental centre, date and time.
- Programming for 4 different users and configuration of instruments for each one.
- Programming of ultrasound work parameters in ENDO, PERIO, SCALER, work range, and instrument light intensity.
- Adjustment of micromotor work parameters (with ENDO functions): torque control in Ncm, direct or reverse rotation, irrigation mode (spray/water), type of counter-angle and two types of speed: from 200 to 40,000 rpm and from 100 to 4,000 rpm.
- Graphic display of ultrasound power level and real turbine working speed.
- Statistics of the use of the unit: chair movements, instrument use, frequent warnings and recent warnings.
- System for detecting and controlling faults or warnings.
- Choice of language for working.
- Countdown function.
- Electronic adjustment of the cup water filling time and spittoon bowl flush with combined or individual setup.
- "Update Device" system: includes the latest programming updates even years after purchase.
- Automatic "Chip-blower" programming.

ERGONOMICS

- Electrically – operated chair with trendelenburg and 5 position memories (three for working, reset and return to cuspidor).
- Multi – position articulated head with minimum height of 365 mm, facilitating treatments in the upper pieces.
- Water box with 70° turn making assistant's work easier.
- Chair movements available on control pedal and keypad (principle and assistant).
- Arm and instrument tray with mechanical compensation and pneumatic brake: better handling with less effort.
- Optional right-side arm turning through 180°.
- Cannulas arm with adjustable height (3 positions).
- Ergonomic headrest at the same level as the optional backrest.
- Optional tight backrest.

SAFETY FEATURES

- In support of auxiliary cannula, back and lower part of the chair.
- Of movements by main and auxiliary keyboard.
- On optional instruments (turbine, micromotor and ultrasound) through adjustor pedal.
- In choosing a second instrument.
- Unit manufactured according to the Medical Devices Directive 93/42/EEC, which design and construction meet applicable safety requirements of dental product regulations and IEC standards.

HYGIENE

- Removable and autoclavable silicone instrument mat.
- Standard suction hoses removable and thermo disinfected.
- Easy-clean suction filter.
- Removable spittoon bowl tray self-fixing at 135°.
- Removable cup filler for easy cleaning.
- Rotary instrument oil recuperator.
- Designed for easy cleaning and disinfection.
- "WEK" optional system for decontaminating water in instrument hoses.
- Optional "H1" system for disinfecting suction hoses.
- Amalgam separation for wet or dry suction systems.

MATERIALS

- ALUMINIUM CORE: Unit, chair and pedal manufactured in light anti-corrosive aluminium alloy.
- Porcelain cuspidor bowl.
- "Standard" and "Soft drive" upholstery, high quality and hygienic, fireproof, steam and air permeable, highly elastic and pleasant feel.



DIMENSIONS

Sd-300 Touch Expert

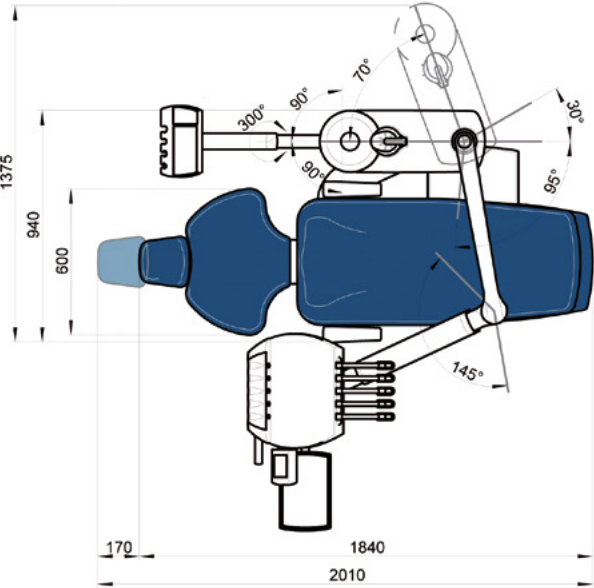
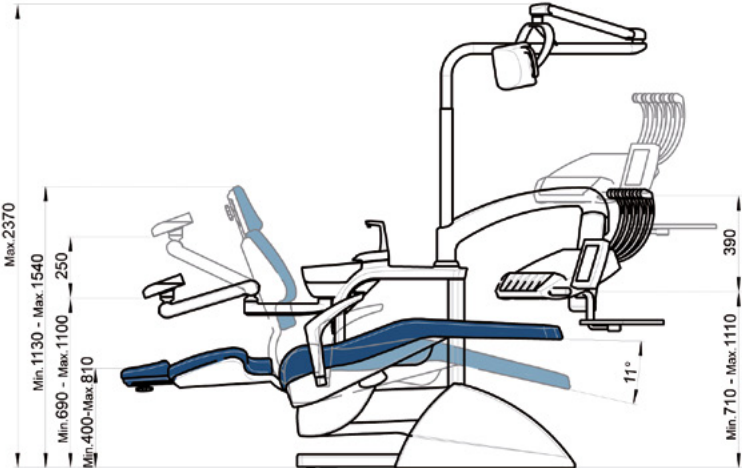

Sd-350 Touch Expert

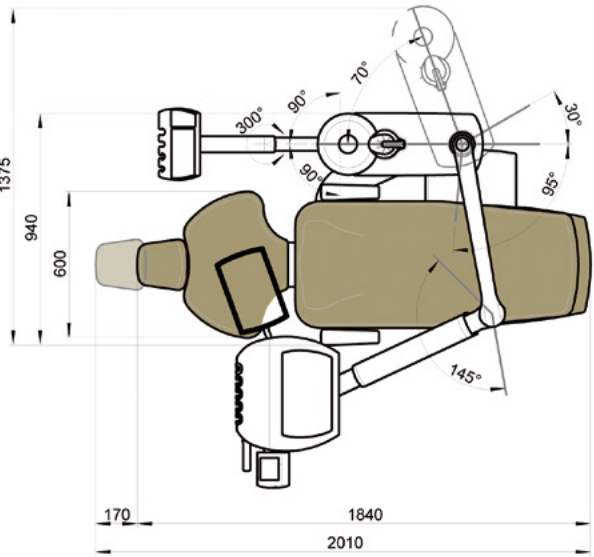
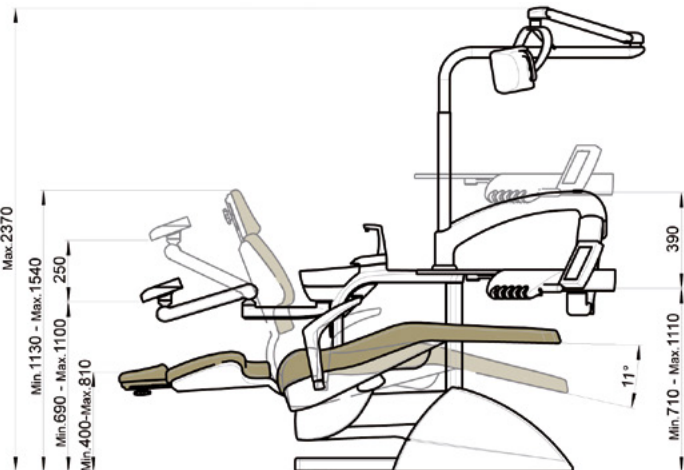

Sd-80 Touch Expert

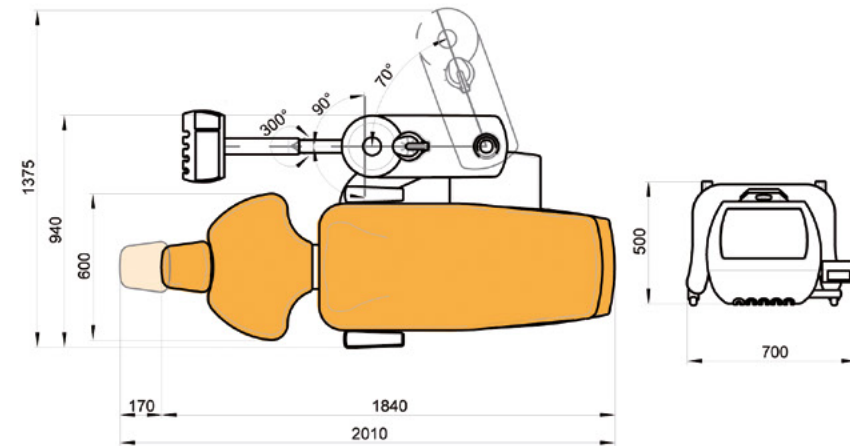
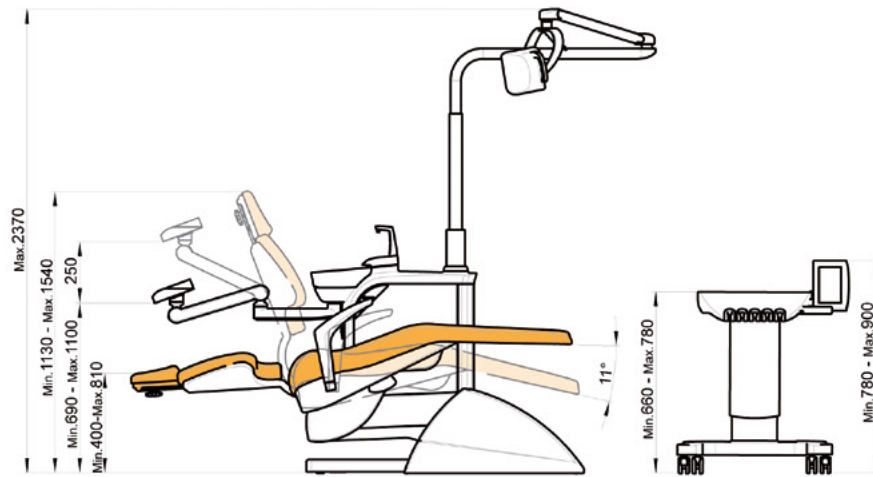

TECHNICAL DATA

| | | | |
|--------------------------------|------------------------------|---|-----------------------------------|
| Voltage | 220 - 240 V~ | Unit standard 93/42/EEC | Ila Class |
| Frequency | 50 Hz | Insulation type | BF Type |
| Air pressure | 5,5 Bar | Unit net / gross weight | 240 kg / 290 kg |
| Water pressure | 3 Bar | Dental unit type | Electronic |
| Power | 900 W | Installation type | Permanent |
| Electrical protection type | I | Main fuse | T 6.3 A / 250 V |
| Operation type | Intermittent | Movement panel fuse, line 24v | T 32 mA / 250 V |
| Maximum load (patient) | 160 kg | Primary transformer fuse, 9015136 PCB | TT 2.5 A / 250 V |
| Maximum load (instrument tray) | 2 kg | 24 V ac 1st line protection (yellow/blue) | Polyswitch RUE400 |
| Instrument Electric Micromotor | 24 Vdc / 65 W | 24 V ac 2nd line protection (blue/brown) | Polyswitch RUE400 + RUE600 |
| Instrument Mx micromotor | 24 Vdc / 60 W (130 max peak) | 17 V ac line protection (red/red) | Polyswitch RUE600 + RUE185 |
| Instrument light | 3v - 7v / 2.5 W | Auxiliary outputs 24 Vac | 4 x water unit |
| Ultrasound | 24 Vac / 35 W | Suction connection | 3 x instrument tray |
| Polymer lamp | 24 Vac / 150 W | Auxiliary contact volt free (circuit box PCB) | 1 x circuit box |
| Syringe 6F | 24 Vac / 150 W | Main electro-valves (ref. 9004889) | 500 W / 230 V Relays 20 A / 250 V |
| | | | Max 250 V / 5 A |
| | | | 24 Vdc |



WE CARE ABOUT YOU

www.ancar-online.com



Check conditions with
the official distributor.



QS4 LEA o88. V1

Subject to design and/or specifications changes without
prior notice. Made in Europe. 6th Edition January 2018.

Antoni Carles, S.A.
Volta dels Garrofers, 41-42 Polígono Industrial "Els Garrofers"
08340 Vilassar de Mar (Barcelona-SPAIN)
Tel. (34) 93 754 07 97 Fax (34) 93 759 26 04
www.ancar-online.com / e-mail: ancar@ancar-online.com